

# PS200 HR/C

Solar-operated Submersible Pump System, 4"  
Helical Rotor (HR) or Centrifugal (C) Pump Unit

## Characteristics

- lift up to 50m
- flow rate up to 5.0m<sup>3</sup>/h
- simple installation
- maintenance-free
- high reliability and life expectancy
- cost-efficient pumping

## Applications

- drinking water supply
- livestock watering
- pond management
- irrigation
- etc.

## Components

### Controller PS200

- controlling of the pump system and monitoring of the operating states
- mounted at surface (no electronic parts submerged)
- two control inputs for well probe (dry running protection), float or pressure switches, remote control etc.
- automatic reset 20 minutes after well probe turns pump off
- protected against reverse polarity, overload and high temperature
- speed control, max. pump speed adjustable to reduce flow rate to c. 30%
- solar operation: integrated MPPT (Maximum Power Point Tracking)
- battery operation: low voltage disconnect and restart after battery has recovered
- max. efficiency 92% (motor + controller)
- enclosure: IP 54 (sealed, weatherproof)

### Motor ECDRIVE 200HR/C

- brushless DC motor
- no electronics inside motor
- water filled
- IP68, pressure balanced, unlimited submersion
- dynamic slide bearings, material: carbon/ceramic
- wetted material: stainless steel (AISI 316), POM, rubber, cable drinking water approved

### Pump End (PE)

- high life expectancy
- non-return valve
- dry running protection (optional)
- material: stainless steel (AISI 316), rubber

### HR Pumps Only

- helical rotor pump (positive displacement pump)
- two main parts only: stator and rotor, field serviceable
- stator: geometry made of abrasion resistant rubber
- rotor: stainless steel, hard chrome plated, abrasion resistant
- more resistant to damage by sand than other pump types
- self-cleaning

## Performance

PS200	HR-04	HR-07	HR-14	C-5-4
article #	1007-X	1009-X	1008-X	1205
lift [m]	0-50	0-30	0-20	0-15
max. flow rate [m <sup>3</sup> /h]	0.8	1.2	2.7	5.0
max. efficiency [%]	60	61	62	45
solar operation	nominal voltage 24-48V DC, open circuit voltage max. 100V DC			battery operation
solar generator [Wp]	80-300	80-300	80-300	only
battery operation	nominal voltage 24-48V DC			



## System Sizing Table: Battery Operation

PS200 HR, 24 V, Battery Operation

vertical lift		pump type	peak flow rate		power [W]	wire size [mm <sup>2</sup> ]
[m]	[ft]		[l/min]	[US Gal./min]		
5	16	HR-04	5.5	1.5	24	2.5
		HR-07	7.5	2.0	37	
		HR-14	17.5	4.6	40	
10	33	HR-04	5.2	1.4	29	2.5
		HR-07	7.5	2.0	42	
		HR-14	16.6	4.4	55	
15	50	HR-04	4.8	1.3	34	2.5
		HR-07	7.0	1.8	50	
		HR-14	15.2	4.0	74	
20	65	HR-04	4.5	1.2	38	2.5
		HR-07	6.5	1.7	60	
		HR-14	12.5	3.3	91	
30	100	HR-04	4.2	1.1	48	4.0
40	130	HR-04	3.8	1.0	58	4.0
50	165	HR-04	3.3	0.9	65	4.0

PS200 HR, 48 V, Battery Operation

vertical lift		pump type	peak flow rate		power [W]	wire size [mm <sup>2</sup> ]
[m]	[ft]		[l/min]	[US Gal./min]		
5	16	HR-04	11.0	2.9	55	2.5
		HR-07	17.0	4.5	90	
		HR-14	38.4	10.1	130	
10	33	HR-04	10.3	2.7	70	2.5
		HR-07	16.5	4.4	100	
		HR-14	36.1	9.5	165	
15	50	HR-04	10.1	2.7	80	2.5
		HR-07	15.8	4.2	115	
		HR-14	35.0	9.2	195	
20	65	HR-04	9.8	2.6	90	2.5
		HR-07	15.5	4.1	135	
30	100	HR-04	9.3	2.5	105	4.0
		HR-07	14.2	3.8	160	
40	130	HR-04	8.7	2.3	125	4.0
		HR-07	13.5	3.6	190	
50	165	HR-04	7.8	2.1	140	4.0

PS200 C-5-4, 24 to 48V, Battery Operation

lift		20V				20V				20V			
[m]	[ft]	power [W]	flow rate			power [W]	flow rate			power [W]	flow rate		
			[l/min]	[US Gal./min]	[Imp. Gal./min]		[l/min]	[US Gal./min]	[Imp. Gal./min]		[l/min]	[US Gal./min]	[Imp. Gal./min]
2.5	8	130	52	13.7	11.4	192	62	16.4	13.6	278	65	17.2	14.3
5	16	140	43	11.4	9.5	206	55	14.5	12.1	278	63	16.6	13.9
8	26	140	38	10.0	8.4	206	49	12.9	10.8	278	59	15.6	13.0
10	33	132	31	8.2	6.8	205	45	11.9	9.9	276	55	14.5	12.1
13	43	130	20	5.3	4.4	204	39	10.3	8.6	270	50	13.2	11.0
15	49	120	10	2.6	2.2	200	34	9.0	7.5	268	45	11.9	9.9
18	59					190	25	6.6	5.5	247	35	9.2	7.7
wire size		use min. 4mm <sup>2</sup> / AWG #10 cable; max. length 15m / 50ft											

### For Battery and Solar Direct Systems

#### Lift Limits

These systems are selected for optimum performance. To allow unexpected drawdown, each system can handle an additional 15 % lift.

#### Higher Lift? Higher Flow Rate?

Choose PS600/1200 for higher lift, higher flow rate applications and lower cable cost.

#### Wire Sizes

Cable Layout is calculated to stay within 4 % power loss.

#### Variations of Length

Longer: for each 50 % increase, the next larger wire size is required

Shorter: for each 33 % decrease, the next smaller wire size is required

Array To Controller: if shorter than 6 m / 20 ft: 4 mm<sup>2</sup> / #10 min.

Controller To Low-Water Probe: 1 mm<sup>2</sup> / #18 min. 2-conductor

### For Solar Direct Systems

#### System Voltage

24-48 V nominal, e.g. 2 to 4 standard 12 V modules wired in series, Voc 100 V max.

#### How Daily Water Volume Is Calculated

Daily volume is calculated by integrating real flow versus realistic solar (PV) output through the day.

The solar array is fixed at tilt angle = latitude of the location.

irradiation:  
kWh/m<sup>2</sup>/day = peak sun hours/day

Flow rates may vary +/- 10 %.

### System Sizing Table: Solar-direct operation

PS200 HR, 24V nominal voltage  
2x 12V standard modules in series

irradiation 4.0 kWh/m<sup>2</sup>/day, tilted surface

vertical lift		pump type	peak flow rate	flow rate for PV array power peak [m <sup>3</sup> /day]			wire size
[m]	[ft]			[l/min]	80Wp	120Wp	
5	16	HR-04	7.2	2.2	2.5	2.8	2.5
		HR-07	13.0	2.0	3.5	4.7	
10	33	HR-04	6.5	2.0	2.3	2.6	2.5
		HR-07	13.0	1.7	3.0	4.2	
15	50	HR-04	6.0	1.8	2.0	2.4	2.5
		HR-07	12.0	1.5	2.8	3.9	
20	65	HR-04	5.8	1.4	1.6	2.2	2.5
		HR-07	12.0	1.1	2.5	3.7	
25	82	HR-04	5.7	1.1	1.5	2.1	2.5
30	100	HR-04	5.5	0.8	1.2	2.0	2.5
40	130	HR-04	5.1	-	1.0	1.8	4.0
50	165	HR-04	5.1	see 36-48V table			4.0

irradiation 6.0 kWh/m<sup>2</sup>/day, tilted surface

vertical lift		pump type	peak flow rate	flow rate for PV array power peak [m <sup>3</sup> /day]			wire size
[m]	[ft]			[l/min]	80Wp	120Wp	
5	16	HR-04	7.2	3.5	3.8	4.0	2.5
		HR-07	13.0	4.0	6.0	7.0	
10	33	HR-04	6.5	3.3	3.6	4.0	2.5
		HR-07	13.0	3.9	5.2	5.4	
15	50	HR-04	6.0	2.9	3.5	4.0	2.5
		HR-07	12.0	3.5	5.0	5.2	
20	65	HR-04	5.8	2.5	3.3	3.9	2.5
		HR-07	12.0	2.4	3.8	4.9	
25	82	HR-04	5.7	2.2	3.0	3.5	2.5
30	100	HR-04	5.5	1.9	2.8	3.1	2.5
40	130	HR-04	5.1	-	2.0	2.5	4.0
50	165	HR-04	5.1	see 36-48V table			4.0

PS200 HR, 36-48V nominal voltage  
2x 12V standard modules in series

irradiation 4.0 kWh/m<sup>2</sup>/day, tilted surface

vertical lift		pump type	peak flow rate	flow rate for PV array power peak [m <sup>3</sup> /day]			wire size
[m]	[ft]			[l/min]	150Wp	200Wp	
5	16	HR-04	12.0	4.8	5.4	6.4	2.5
		HR-07	19.5	4.7	7.0	8.5	
10	33	HR-04	11.8	4.5	5.0	6.0	2.5
		HR-07	19.0	4.2	6.0	7.5	
15	50	HR-04	11.5	4.0	4.6	5.7	2.5
		HR-07	18.5	3.9	6.0	7.4	
20	65	HR-04	11.5	3.5	4.2	5.4	2.5
		HR-07	18.0	3.3	5.5	7.0	
25	82	HR-04	11.3	2.6	3.6	5.1	2.5
		HR-07	17.5	-	2.5	4.0	
30	100	HR-04	11.0	2.0	3.0	4.8	2.5
40	130	HR-04	11.0	1.7	2.4	3.5	4.0
50	165	HR-04	10.5	1.3	2.0	3.0	4.0

irradiation 6.0 kWh/m<sup>2</sup>/day, tilted surface

vertical lift		pump type	peak flow rate	flow rate for PV array power peak [m <sup>3</sup> /day]			wire size
[m]	[ft]			[l/min]	150Wp	200Wp	
5	16	HR-04	12.0	6.3	6.6	7.3	2.5
		HR-07	19.5	8.5	9.5	10.5	
		HR-14	36.0	11.0	15.0	18.0	
10	33	HR-04	11.8	6.0	6.5	7.0	2.5
		HR-07	19.0	8.0	9.0	10.0	
		HR-14	34.0	9.0	13.0	16.0	
15	50	HR-04	11.5	5.5	6.0	6.8	2.5
		HR-07	18.5	7.0	8.3	9.5	
		HR-14	33.0	8.0	11.0	14.0	
20	65	HR-04	11.5	5.5	6.2	6.6	2.5
		HR-07	18.0	6.0	7.5	9.0	
25	82	HR-04	11.3	5.0	5.6	6.2	2.5
		HR-07	17.5	5.0	6.5	8.0	
30	100	HR-04	11.0	4.3	4.9	5.8	2.5
40	130	HR-04	11.0	3.0	4.0	5.0	4.0
50	165	HR-04	10.5	2.0	3.0	4.2	4.0

#### Conversion for Wire Sizes

AWG	mm <sup>2</sup>
# 18	1
# 12	4
# 10	6
# 8	10
# 6	16

#### Conversion for Flow Rates

1 m <sup>3</sup>	264 US Gal.
1 m <sup>3</sup>	220 Imp. Gal.
1 l/min	0.264 US Gal./min
1 l/min	0.220 Imp. Gal./min

#### Conversion for Lift/Length

1 m	3.3 ft
-----	--------

Table shows nearest larger metric cross section.

**Dimensions and Weights**

	dimensions					shipping dimensions			
	L	A	B	D	S	packaging	shipping volume	net weight	gross weight
	[mm]	[mm]	[mm]	[mm]	[mm]	[mm]	[m <sup>3</sup> ]	[kg]	[kg]
<b>Pump Unit (PU) (motor + pump end)</b>									
HR-04	780	595	185	96	G 1 1/4"	850×160×150	0.0204	11.2	12.0
HR-07, HR-14	771	586	185	96	G 1 1/4"	850×160×150	0.0204	11.5	12.3
C-5-4	527	342	185	96	G 1 1/4"	660×160×150	0.0158	10.0	10.5
<b>Controller</b>									
PS200						320×240×160	0.0123	1.2	1.8

By cutting the rubber spacers, diameter can be adjusted from 147mm (6") to 100mm (4")

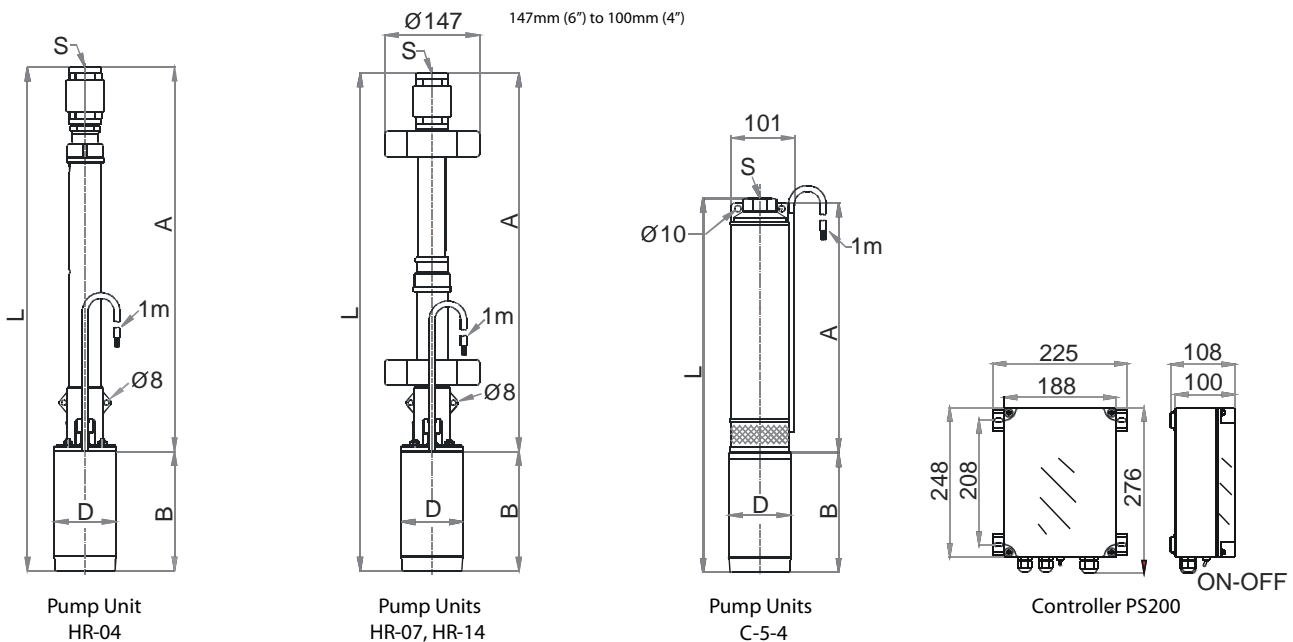

**Sand and Silt Tolerance**

The pump (HR) has a higher resistance to wear from sand, clay etc. than any other pump type. In properly constructed wells the amount of solid particles is within the tolerance of the pump.

A concentration of particles higher than 2% (by volume) may cause blockage in the pump or the drop pipe, especially at low flow rates.

Do not use the pump to clean out a dirty well.

**Pump Cable and Splice**

Standard submersible cable, 3-wire + ground (total four wires). Connection to the pump is made using industry-standard splicing methods.

**Drop Pipe**

G 1 1/4" (optional: 1" NPT) pump outlet. If water is dirty consider a smaller sized drop pipe to increase the flow velocity. This helps to exhaust solid particles and prevent accumulation in the pipe. When considering reduced pipe size, consult a pipe sizing (friction loss) chart. Pipe can be of any standard material, rigid or flexible. A torque arrestor is not required.

**Temperature Limits**

Pump end, motor: water temperature up to +40°C (+104°F)

Specify temperature range on order.

Controller: ambient temperature -30°C to +55°C (-22°F to +131°F)

**Warranty**

Two years manufacturer's warranty against defects in material and workmanship

Distributed by,

**GREEN ENERGY LLC**

GF 9&12, 4B Dubai Creek Tower  
Dubai, UAE

Ph : +971 4 229 6629 / 228 2456

Fax : +971 4 221 5234 / 227 9525

info@ptlsolar.com

